

PM Formalization of Micro Food Processing Enterprises (PMFME) Scheme



Liquid Milk Processing (Pouch, Bottle & Aseptic Pack)

Prepared by:

(Nitin Kumar, Assistant Professor, NIFTEM)

National Institute of Food Technology Entrepreneurship and Management
Deemed to be University (De-novo Category) under Section 3 of the UGC Act, 1956
An Autonomous Institution under Ministry of Food Processing Industries, Government
of India, Sonapat, Haryana, India

Contents

Chapter – 1: Raw Material

1.1	Introduction.....	04
1.2	Dairy Industry in India.....	04
1.3	Insight on value-added product.....	05
1.4	Export-import opportunities.....	05
1.5	Key deterrents to the growth of the market.....	05
1.6	Need for Processing Milk.....	06
1.7	Composition of Milk.....	06
1.8	Nutritional Value of Milk.....	06

Chapter – 2: Processing and Machinery

2.1	Introduction.....	08
2.2	Different departments in a unique dairy processing plant.....	08
2.3	Different operations in milk processing unit.....	09
2.4	Milk pasteurization.....	11
2.5	Cream Separation.....	13
2.6	Homogenization.....	14
2.7	Standardization.....	14
2.8	Calculation for standardization.....	15
2.9	Different tests carried out to assure the quality of processed milk.....	16
2.10	Packing machines.....	18

Chapter – 3: Food Safety Regulations and Standards

3.1	Registration and licensing of food business.....	21
3.2	Hygienic and Sanitary Practices.....	22
3.3	Packaging and Labelling.....	25
3.2	Selection of packing material.....	27
3.3	Coding and labelling.....	27
3.4	Exemption from labelling requirement.....	28
3.5	Date of manufacturing on packing material.....	29
3.6	Documentation and record keeping.....	31

Chapter – 4: Cleaning, CIP and Effluent Treatment

4.1 Tanker washing.....	32
4.2 Crate washing.....	32
4.3 CIP of Raw and Process milk tanks/silos.....	32
4.4 Effluent Treatment Plant.....	33

Chapter – 1

Raw Material

1.1 Introduction

Milk, liquid secreted by the mammary glands of female mammals to nourish their young for a period beginning immediately after birth. The milk of domesticated animals is also an important food source for humans, either as a fresh fluid or processed into a number of dairy products such as butter and cheese (<https://www.britannica.com>). Milk is a nutritious choice as it provides nine essential nutrients our body needs. Milk contains essential nutrients like high-quality protein, calcium, vitamin D and more. These nutrients help our bodies function properly. For example: Protein helps build and repair muscle tissue Calcium and vitamin D helps build and maintain strong bones and teeth Milk also contains B vitamins, which can help your body convert food into energy.

1.2 Dairy Industry in India

India is leading milk producing country in the world, accounting for 19 percent of the global market share and expected to grow at compound annual growth rate (CAGR) of 14.8% between FY 2018 – 2023. As per fiscal year 2019, milk production in India amounted to about 187 million metric tons. As per FY – 2018, around 81% of the Indian dairy and milk processing market comes under unorganized sector, where milk is processed in unhygienic infrastructure, which affects the overall quality of milk and milk-based products. Consumption patterns of liquid milk at the farm level and less infrastructure for processing is the main reason for low value addition of milk. The demand for value added products especially traditional dairy products is increasing day by day and the dairy industry of the country is trying to meet the present demand.

Uttar Pradesh, Rajasthan and Gujarat are the major milk producing states in India. Uttar Pradesh is the largest milk-producing state, as it has the highest buffalo population and the second-highest cattle population in the country. Majority of the rural population in this state is engaged in livestock nurture and dairy farming. Gujarat holds several cooperative dairy unions, milk cooperative societies and private dairy plants, which play vital roles in the production of milk and milk-based products in the state.

1.3 Insight on value-added product

Apart from processed liquid milk, Indian dairy and milk processing industry generates revenue from several value-added products such as butter, curd, paneer, ghee, whey, flavoured milk, ultra-high temperature (UHT) milk, cheese, yogurt, dairy whitener and milk powder. During the FY 2016 – 2020, the market size of dairy ingredients is expected to grow by around 14%.

1.4 Export-import opportunities

The export of dairy products from India has increased to countries like Bhutan, Afghanistan, Canada, Egypt, and the United Arab Emirates. India has also imported a significant number of dairy products from countries like France, New Zealand, Ireland, France, Ukraine, and Italy.

1.5 Key deterrents to the growth of the market

Despite having a significant livestock base of milch animals, India lacks in terms of good processing facility and availability of cold storages which results in wastage of dairy output. Lack of sufficient storage facilities and inefficient distribution channels are hampering the growth of the Indian dairy and milk processing industry.

Sufficient quantity and good quality of feed and fodder are required for proper animal rearing and milk production. Improper droughts and flood management affect the production of fodder in India. Deficiency of proper feed and fodder for milch animals, due to high usage of agricultural crop residues by producers of fibreboard, paper, and liquid fuels, affect its availability for dairy production and milk processing.

Dairy marketing channels in India

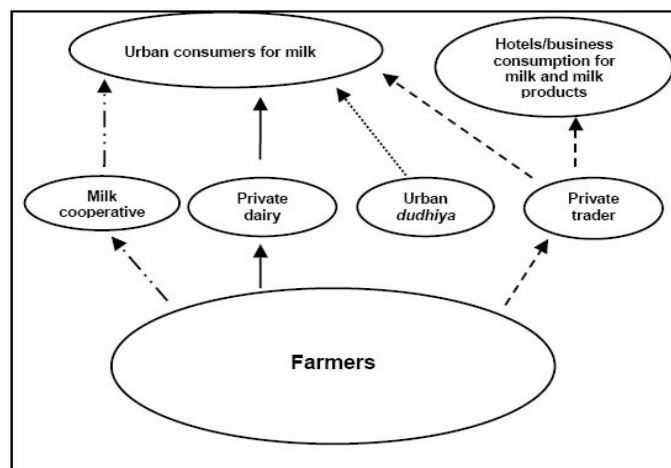

Reference: FAO

1.6 Need for Processing Milk

Milk is considered wholesome food mainly because of its high nutritive value. It has to be processed to;

- Increase the shelf life, because it is highly perishable.
- Prepare value added products like dahi, cheese, paneer, butter, ghee, AMF, flavoured milk, cheese, and yogurt, dairy whitener, milk powder etc. and many more dairy based products, for a good health.
- Make business out of it, create job opportunities, consequently building financially strong Nation.

1.7 Composition of Milk

Milk composition varies with species, breed (Holstein, Jersey), feed, and the stage of lactation. As per FSSAI, “Milk is a whole, fresh, clean lacteal secretion obtained by complete milking of one or more healthy milch animals excluding that obtained within 15 days before calving or 5 days after calving. Market milk must possess the pre-determined percentage of milk fat and SNF (Solid Not Fat).”

Milk of different classes and types must conform to the standards laid down by FSSAI. Mixed milk means a combination of the milk from cow and buffalo or any other milch animal. The combination also should at par with FSSAI standards.

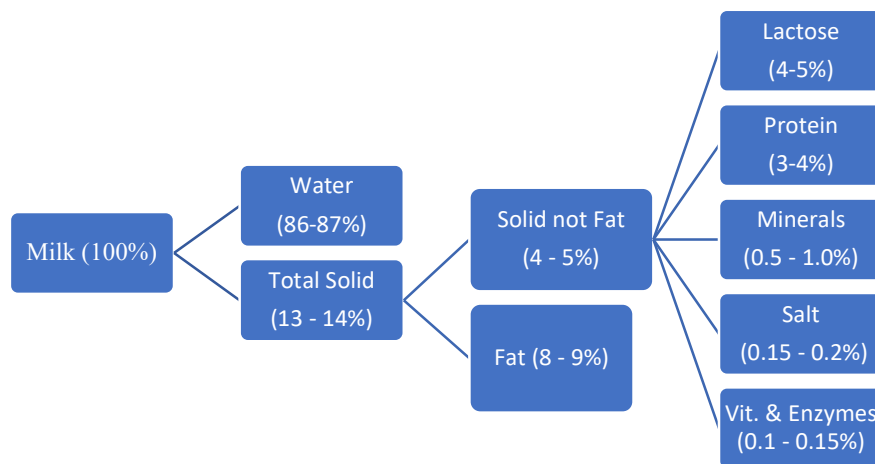

1.8 Nutritional Value of Milk

Table: Nutritional values of milk

Nutritional Factor	Description	Energy Value
Protein	Milk protein is casein, a high-quality protein. All essential amino acids are present in Milk.	4.1 kCal/g
Minerals	Milk contains phosphorus and calcium.	
Vitamins	Milk contains vitamins A, D, thiamine, and riboflavin.	
Fat	Milk fat is responsible of good flavor and physical properties. The fat content in cow milk is generally from 3.5 to 4.5 %	9.3 kCal/g
Lactose	Lactose is the sugar component of milk and it supply energy.	4.1 kCal/g

Chapter – 2

Processing and Machinery

2.1 Introduction

Primary processing is basically referred as Pasteurization of milk. Cream Separation, Standardization and Homogenization are intermediate process of pasteurization

2.2 Different Departments in a unique Dairy Processing Plant

Production is the main body of any food processing unit. Based on the capacity and product variants, different supporting departments made to deliver right product at right time to the consumer and consequently generate revenue. Departments are majorly categorized into;

1. Production and Operation: Production planning, Scheduling, managing daily production
2. Quality Assurance and Regulatory: Assure quality of the product, establish food safety, organizing internal audits, Certifications (FSSAI, FSSC 22000, AGMARK, Halal, BRC etc.) and updating of food safety manual
3. Research and Development: New Product development
4. Engineering
 - a. Engaged in new projects
 - b. Maintenance of the machinery and infrastructure
 - c. Managing water treatment plant (WTP)
 - d. Managing power supply unit (UPS, Generators, Solar panels, and coordination with electricity board)
5. Procurement: Engaged in procurement of raw material, packing material, engineering items, vendor development etc.
6. Store: Maintaining the inventory and alarm procurement, maintaining FIFO, LIFO etc.
7. Logistic and Supply Chain: Deliver products to the consumer at right time
8. Sales and Marketing: Manager is responsible for researching and developing marketing opportunities and planning and implementing new sales plans.
9. Safety Health and Environment (SHE): Ensure safety personnel, premises and environment, coordinating with Pollution control board
10. Human Resource and Legal

Role and Responsibilities:

- Recruitment: To ensure that right people are recruited for right position and in right number to meet the requirement.
- Medical examination and health card record keeping: Medical examination of the employee is carried out to ensure that they are medically fit to carry out their work.
- Contract labour engagement: To describe a procedure for contract labour engagement.
- Attendance and leave policy: To describe a procedure for monitoring the employees the punctuality and discipline.
- Training for Roll and contractual labour employees: To describe a procedure for carrying out training for all employees and to ensure proper training records are maintained at plant level.
- Skill matrix: To ensure the effectiveness of occupational/working skill for employee.

2.3 Different operations in milk processing unit

Raw Milk Reception Dock (RMRD)

Milk reception in India is basically done in two ways i.e., with milk cans and milk tankers. Tankers are of different capacity and single compartment to three compartments.

Responsibilities at RMRD

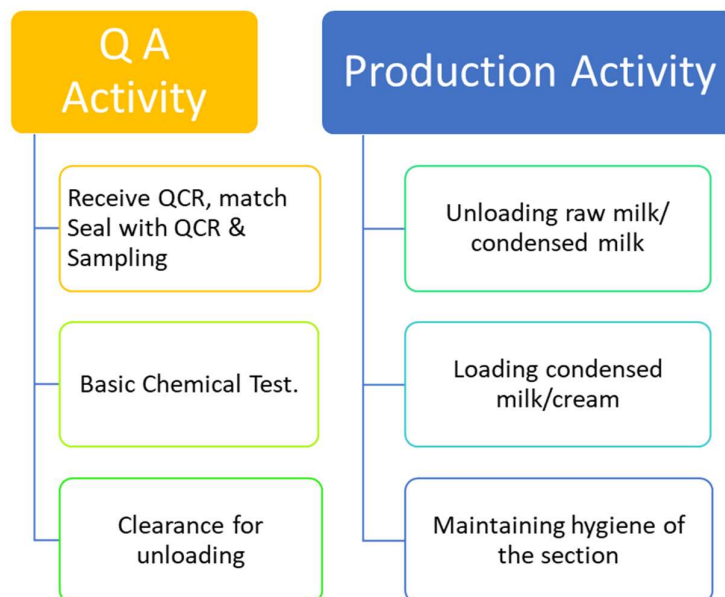

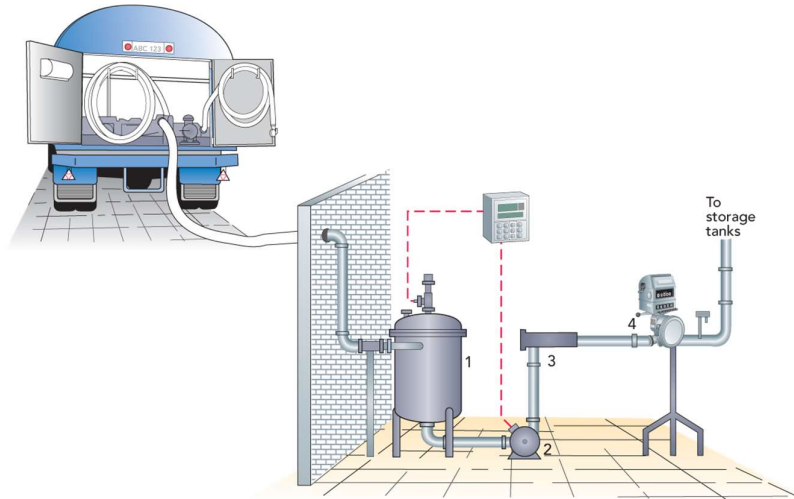

Fig: Raw milk reception dock. 1. De-aeration tank or air eliminator 2. Pump 3. Filter 4. Mass flow meter

Sampling and Quality Testing

Sample from all the compartments of the tanker are collected after mixing (normally called plunging) the milk for 10-15 min. in a and following tests are conducted.

- 1) Methylene Blue reduction Test (MBRT): This test is done to find the microbial load in the raw milk. (10ml milk + 1ml methylene blue) is heated at 36-37 degree Celsius and change in colour is observed. The quicker will be the colour removed the higher will be the microbial load.
- 2) Delvo Test: This test is done to find the presence of antibiotics in milk.
- 3) Temperature measurement: It should not be more than 6 degree Celsius.
- 4) Determination of Fat, SNF and protein using equipment like milkoscan or equivalent.
- 5) Organoleptic Test: This test is done to find taste, flavor and appearance i.e. normal pleasant test/sour/sweet/salty/bitter/abnormal test.
- 6) Acidity test: Reading 0.130-0.148 is accepted while 0.150 and above is rejected.
- 7) Alcohol Test: (5ml milk+5ml alcohol) is mixed and appearance of any clot or flake is observed. The presence of any flakes or clots shows appositive test.
- 8) Clot and Boiling (COB) Test: 5ml of sample is taken in attest tube and kept in boiling water for 5 min. The formation of clot denotes a positive test. A positive COB test has acidity above 0.17% as lactic acid and is not suitable for distribution as liquid milk or for processing.
- 9) Neutralization Test: (5ml milk + 5ml alcohol + 5ml rosalic acid) is mixed; a red rose colour shows the presence of Carbonates.

10) Preservative Test: (10ml milk in wide mouth test tube + 5ml concentrated sulphuric acid); observe the colour at the junction of two liquid. The presence of violet or blue colour indicates the presence of Formaldehyde.

11) Adulteration Test:

- a. Sugar: (15ml well mixed milk in test tube + 0.1ml concentrated hydrochloric acid + 0.1gm resorcinol) place the tube in the boiling water bath for 5min. appearance of red colour shows presence of sugar.
- b. Starch: (5ml milk is boiled in water bath and cooled to room temperature) + a drop 1% iodine solution. Observe the presence of blue colour in the presence of starch which disappears on boiling and appears on cooling.
- c. Salt: (5ml silver nitrate + 2drops indicator solution + 1ml milk) keep for 2 min. the formation of pale-yellow colour indicates salt +ve and if colour remains brownish, salt test is –ve.
- d. Urea Test: (5ml milk + 5ml dimethyl amino benzaldehyde) mix properly and observe the colour change. The presence of bright yellow colour shows Urea +ve.

2.4 Milk Pasteurization

The French Scientist Louis Pasteur invented the process called pasteurization, during the nineteenth century. Pasteur found that, heating milk to a high temperature and then quickly cooling it before bottling or packaging it could increase the shelf life of milk.

Today, the pasteurisation process is widely used within the beverage and food industry, and is considered as the most common heat treatment process. Pasteurisation ensures, the milk is safe to consume, at the same time increasing its shelf life.

The Pasteurisation process involves heating milk to 72°C for at least 15 seconds (more than 25 seconds). The time temperature combination varies with elevation, the same shall be defined by the process owner and validated. Looking into the nature of the heat treatment, it sometimes referred to as the ‘High Temperature Short Time’ (HTST) process. Once the milk is heated to the defined temperature, it is cooled quickly to less than 3°C temperature. The equipment used to heat and cool the milk is called a ‘heat exchanger’. There are different types of heat exchangers used in process industry. The most commonly used heat exchanger is plate heat exchanger (PHE). It is compact in design and requires less space. Once the milk has been pasteurised it is bottled or packaged to be sold to consumers. The pasteurized milk

is kept below 5°C till it is consumed. The two methods of pasteurization are Batch Pasteurization and Continuous Pasteurization. Commonly used method at industrial scale is continuous pasteurization.

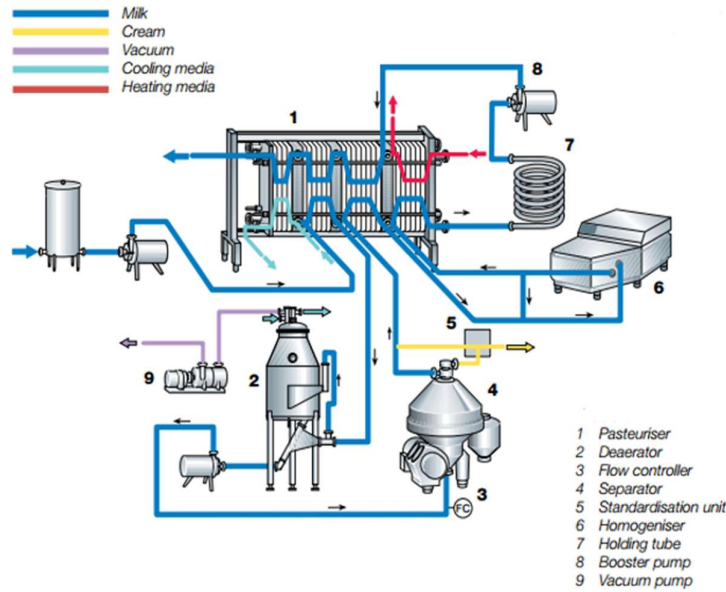

Fig: Typical Milk Pasteurizer Unit

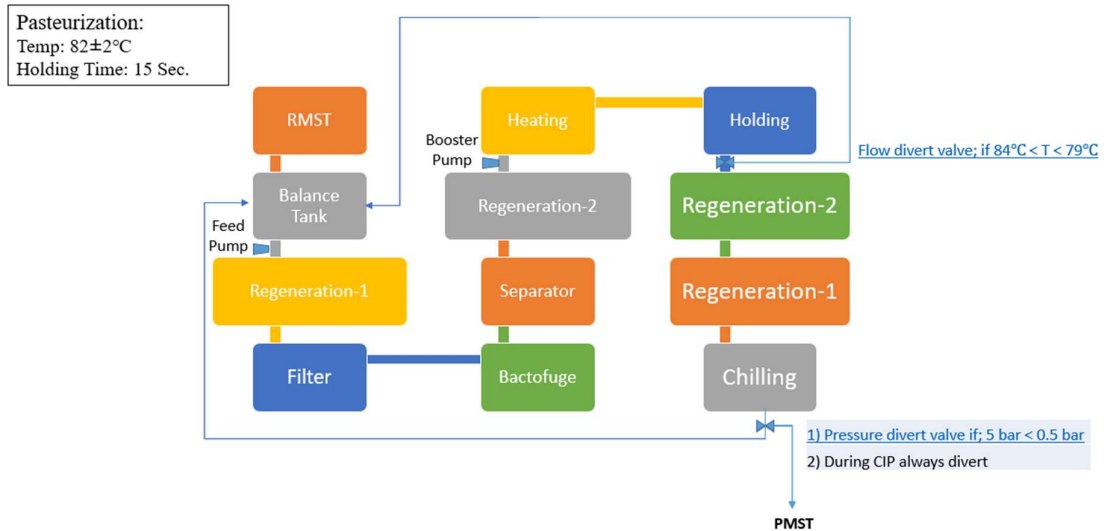

Fig: Typical Milk Pasteurizer Flow Diagram. Indicated temperature and time may vary

2.5 Cream Separation

There are many unit operations in milk processing, cream separation is one among them. At industrial level, it is an intermediate process in pasteurization. Cream separation is mainly done

1. To recover fat from milk: Fat is used to prepare value added products such as ghee, butter, etc.
2. To obtain a low fat or fat-free milk (Skim milk): Skim milk is used to prepare skim milk powder, dairy whitener, condensed skim milk etc.
3. To standardize the fat content of milk.

There are two different methods separate cream from milk;

1. Gravity Method: In this method, milk is hold undisturbed for some time. Cream being lighter than other compositions, comes up and is taken out manually. This is not a controlled method and hence proper separation cannot be ensured.
2. Centrifugal Method: In this method, a centrifugal agitation is given to the milk with some agitator manually or a dedicated machine called cream separator. Cream separator is installed along with pasteurizer, normally after regeneration – 1. The percentage of cream to be separated from the milk can set in the machine.



Fig. Cream Separator

2.6 Homogenization

Homogenization is the process of reducing the size of fat globules in milk. It prevents the formation of a cream layer and easy digestion. Homogenized milk has a uniform flavour throughout. It tastes richer, smoother and creamier than unhomogenized milk due to an increase in the surface area of the fat globules which are uniformly distributed in milk. Homogenizer machine used to perform the process.

According to the United States Public Health Services (USPHS), ‘homogenized milk is one that has been treated in such a manner as to ensure the break-up of the globules to such an extent that after 48 hours of quiescent storage, no visible cream separation occurs in milk and the fat percentage of the milk in the upper 10% portion, i.e., in the top 100 ml of milk in a quart bottle or of proportionate volumes in containers of other sizes, does not differ by > 10% of itself from the fat percentage of the remaining milk, as determined after thorough mixing’.



Fig. Homogenizer

2.6 Standardization

Standardization of milk generally refers to balancing the percentage of fat and solid not fat (SNF), to comply with the legal requirements of market milk. Standardizing milk might require control of only one component (usually fat) while allowing the others to vary or control two or more components simultaneously. Skim milk powder, condensed skim milk and fresh cream is generally to standardize.

Methods of Calculation

For standardization of milk or cream for product manufacture, the proportions of the ingredients of known composition to be mixed, is required to be estimated. This can be done by:

1. Pearson's Square method
2. Algebraic equations

Different Class of Market Milk sold in India

Class of Milk	Designation	Locality	Min %	
			Fat	SNF
Toned Milk	Pasteurised, flavoured and sterilized	All India	3	8.5
Double Toned Milk	Pasteurised, flavoured and sterilized	All India	1.5	9.0
Standardized Milk	Pasteurised, flavoured and sterilized	All India	4.5	8.5
Full Cream Milk	Pasteurised and sterilized	All India	6.0	9

Reconstituted milk: It is the liquid milk obtained by adding water to skim milk powder or whole milk powder.

Recombined milk: It is the liquid milk obtained by adding water to skim milk powder and adding milk fat separately in such a quantity that the desired fat content is achieved.

2.8 Calculation for Standardization

Example - 1:

2000 kg of milk (with 87.6% water, 3.8% fat, 3.2% protein, 4.6% lactose, and 0.7% ash content) has to be reduced in fat content from 3.8% to 2.5% by removal of cream with 40% fat content from the milk. How much milk will have to be removed?

Solution:

$$\text{TMB: } 2000 = C + M$$

$$\text{FMB: } 2000 * 0.038 = 0.4 * C + 0.025 * M$$

$$2000 * 0.025 = 0.025 * C + 0.025 * M$$

Solving the equations will give the values of $C = 69.3$ kg and the remaining milk $M = 1930.7$ kg.

Example - 2:

How much whole milk with 3.9% fat and skimmed milk with 0.04% fat content will you need to produce 2000 kg of standardized milk with 2.5% fat?

Solution:

Using mass balance method:

$$\text{TMB: } W + S = 2000$$

$$\text{FMB: } 0.039 * W + 0.0004 * S = 0.025 * 2000$$

Solving for $W = 1274.6$ kg and $S = 725.4$ kg

Using Pearson’s Square method

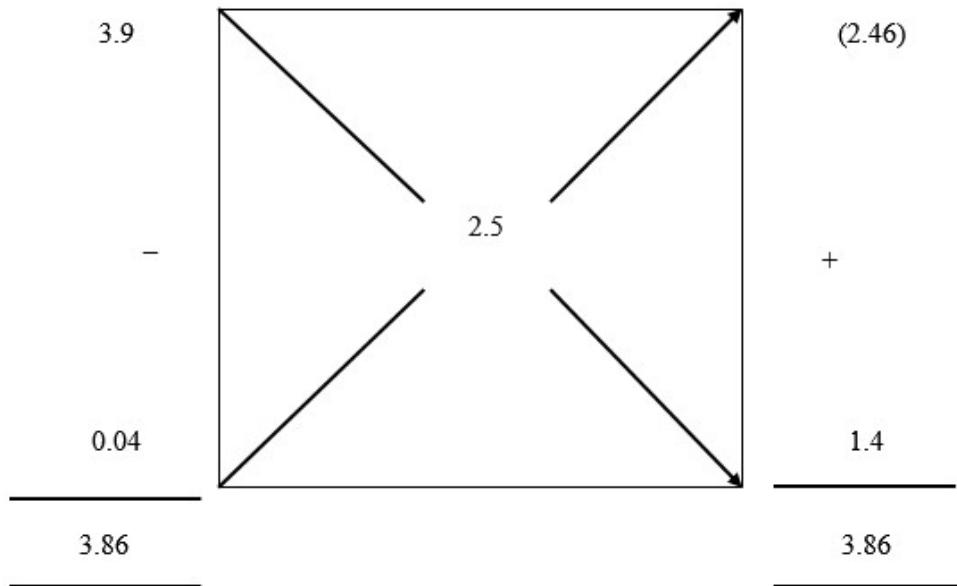

Proportion of the whole milk = $2.46/3.86$

Amount of whole milk required = $(2.46/3.86)*2000 = 1274.6$ kg

Proportion of skimmed milk = $1.4/3.86$

Amount of skimmed milk required = $(1.4/3.86)*2000 = 725.4$ kg

(or $2000 - 1274.6$)

2.9 Different tests carried out to assure the quality of processed milk

- 1) **Organoleptic Test:**Color, taste and flavour of milk
- 2) **Clot and Boiling Test (COB):** To check the clotting of milk. 2ml milk (dry test tube) is boiled on spirit flame. Formation of ppt shows COB test is positive.
- 3) **Acidity test:** Take 20ml milk in 100 ml beaker, add 8 drops of phenolphthalein indicator and titrate with N/10 NaOH till pinkish colour appears.

$$\%TA = 0.045 \times \text{ml of NaOH used}$$

- 4) **Alcohol Test:** 5ml of milk in a test tube is mixed with (60 to 78% by vol.) alcohol with constant shake. Formation of precipitate shows alcohol test positive.
- 5) **Neutralization Test:** 5ml milk in a test tube, add 5ml alcohol and mix it, then add 4 to 5 drops of 1% Rosolic acid. Red rose colour indicates neutralization test is positive and brownish colour shows test is negative.

- 6) **Sugar Test:** 5ml milk in test tube, add a pinch of Resorcinol and conc. HCl. Mix well and keep test tube in boiling water for 5min. brick red color formation shows sugar test positive.
- 7) **Starch Test:** 2 ml milk in a test tube, boil and cool in tap water. Add 3-3 drops of 1% Iodine solution. Appearance of blue color indicates starch test positive.
- 8) **Urea Test:** 2ml milk in test tube, add 2ml DMAB solution and mix the content. Appearance of yellow color indicates urea test positive.
- 9) **Test for detection of (salt) sodium chloride in milk:** In 5ml of 0.134% silver nitrate, add 2-3 drop of 1% potassium chromate. Then add 1ml milk. Appearance of yellow color indicates presence of dissolved chloride.
- 10) **Formalin Test:** 5ml milk in test tube, add 0.5 ml of FeCl₃ solution and mix well. Add conc. H₂SO₄ slowly along the side of tube. Formation of volatile ring at juncture of two liquid confirms the presence of formalin positive.
- 11) **Hydrogen peroxide Test:** 5ml milk in test tube, add 2drop of Paraphenyl diamine hydrochloride (1%). Formation of blue colour indicates hydrogen peroxide is present.
- 12) **Detection of detergent:** 5ml milk in 15ml test tube, add 1ml methylene blue dye followed by addition of 2ml chloroform. Vortex the content for about 15 sec. and centrifuge at about 1100rpm for 30 min. note the intensity of blue colour in lower and upper level. Relatively more intense blue colour in lower layer indicates presence of detergent in milk, whereas more intense blue colour in the upper level indicates absence of detergent.
- 13) **Determination of fat in milk (Gerber method):** 10ml H₂SO₄ in into a butyrometer tube without wetting the neck of the tube. Mix the milk sample (10.75ml at 27-29 °C) gently and fill in the tube. Add 1ml amyl alcohol. Close with a lock stopper, shake well and invert for complete admixture. Centrifuge 5min for raw milk and 10 min for homogenized milk. Take the reading of colour less liquid.
- 14) **Phosphatase test for pasteurization of milk:** Pipette 5ml of buffer substrate solution, bring the temperature to 37⁰C for 2hrs. Incubate one blank prepared from boiled milk of the same type. Remove the milk after 2hrs and content should be well mixed. Place the boiled blank on the left side of the comparator and test sample on the right. Take the reading in reflected light by revolving the disk.
- 15) **Milk homogenization efficiency Test (NIZO Test):** Heat milk to 40⁰C and transfer one portion of milk to 25ml centrifuge tube, keep another portion of the milk for fat

analysis. Centrifuge for 20min in Remi Centrifuge at (1100-1200rpm). Do Gerber milk fat determination for the two portions of the milk?

$$\text{Efficiency \%} = \{(\text{centrifuged milk's fat})/(\text{normal milk's fat})\} \times 100$$

16) **Determination of SNF% in milk:** Warm milk to 29⁰C and mix. Fill the prepared milk in cylinder. Invert the lactometer and allow to float freely. Take lactometer reading and calculate SNF using formula.

For lite curd, dilute milk with distilled water (200ml milk + 100ml distilled water), then follow the procedure to measure LR. Calculate CLR= (LR/2) X 3

For Tamil Nadu and butter milk; SNF% = (CLR/4) + 0.36 + (0.2 X F)

For Karnataka milk; SNF% = (CLR/4) + 0.44 + (0.2 X F)

17) **Methylene Blue Reduction Test (MBRT):** This test is done to get the rough estimation of bacterial load.

(10ml milk + 1ml Methylene Blue) mix well and heat at 37⁰C. Observe the color change.

Greater the no of bacteria in the milk, sooner the colour disappears.

2.10 Packing Machines

Different types of packing machines are used for packing liquid milk. In market, liquid milk is normally available in two forms

1. Pasteurized Milk
2. Ultra-heat-Treated Milk (UHT)

Pasteurized milk is normally packed in multi-layer pouches and bottles (PET bottles, PP bottles and glass bottles), however UHT is packed in aseptic pack like Tetra-bricks, Tetra-fino or equivalent.

Machine used

1. Pasteurized Milk
 - a. Vertical Form Fill Machine (VFFS): It is available in two variants i.e., single head and two head
 - b. Bolling machine: It also comes in two variants i.e., rotary and linear

2. UHT Milk: Aseptic machines are used for UHT milk packing. Aseptic packaging is a procedure consisting of sterilization of the packaging material or container, filling with a commercially sterile product in a sterile environment, and producing containers that are tight enough to prevent recontamination (hermetically sealed)



Single Head VFFS



Double Head VFFS



Aseptic packing Machine



Rotary Bottling machine

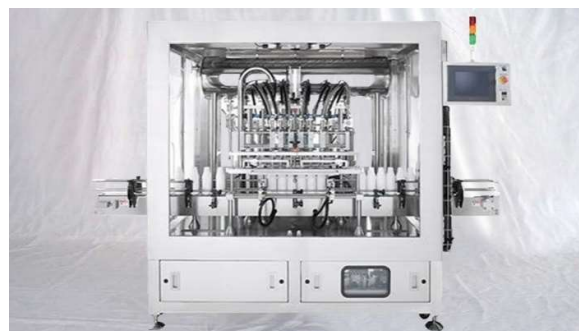

Linear bottle Filling Machine

Chapter – 3

Food Safety Regulations and Standards

3.1 Registration and Licensing of Food Business

All Food Business Operators in the country will be registered or licensed in accordance with the procedures laid down

Registration of Petty Food Business

- a. Every petty Food Business Operator shall register themselves with the Registering Authority by submitting
- b. An application for registration in Form A under Schedule 2 of these Regulations along with a fee as provided in Schedule 3.
- c. The petty food manufacturer shall follow the basic hygiene and safety requirements provided in Part I of Schedule 4 of these Regulations and provide a self-attested declaration of adherence to these requirements with the application in the format provided in Annexure-1 under Schedule 2.
- d. The Registering Authority shall consider the application and may either grant registration or reject it with reasons to be recorded in writing or issue notice for inspection, within 7 days of receipt of an application for registration.
- e. In the event of an inspection being ordered, the registration shall be granted by the Registering Authority after being satisfied with the safety, hygiene and sanitary conditions of the premises as contained in Part II of Schedule 4 within a period of 30days.
- f. If registration is not granted, or denied, or inspection not ordered within 7 days as provided in above sub regulation (3) or no decision is communicated within 30 days as provided in above sub regulation (4), the petty food manufacturer may start its business, provided that it will be incumbent on the Food Business Operator to comply with any improvement suggested by the Registering Authority even later.
- g. Provided that registration shall not be refused without giving the applicant an opportunity of being heard and for reasons to be recorded in writing.
- h. The Registering Authority shall issue a registration certificate and a photo identity card, which shall be displayed at a prominent place at all times within the premises or vehicle or cart or any other place where the person carries on sale/manufacture of food in case of Petty Food Business.

- i. The Registering Authority or any officer or agency specifically authorized for this purpose shall carry out food safety inspection of the registered establishments at least once in a year. Provided that a producer of milk who is a registered member of a dairy Cooperative Society registered under Cooperative Societies Act and supplies or sells the entire milk to the Society shall be exempted from this provision for registration.

3.2 Hygienic and Sanitary Practices

In addition to Part-II, the dairy establishment in which dairy based food is being handled, processed, manufactured, stored, distributed and ultimately sold by the food business operator, and the persons handling them should conform to the sanitary and hygienic requirement, food safety measures and other standard as specified below.

1. Sanitary requirements
 - a. Facilities for the hygienic handling and protection of raw materials and of non-packed or non-wrapped dairy products during loading and unloading, transport & storing including Bulk Milk cooling facilities.
 - b. Special watertight, non-corrodible containers to put raw materials or dairy products intended for human consumption. Where such raw materials or dairy products are removed through conduits, these shall be constructed and installed in such a way so as to avoid any risk of contamination of other raw materials or dairy products;
 - c. A waste water disposal system which is hygienic and approved;
 - d. Facilities for cleaning & disinfecting of tanks used for transporting dairy products and raw milk. These containers have to be cleaned after every use.
 - e. The occupier of a dairy establishment shall take appropriate measures to avoid cross-contamination of dairy products in accordance with the cleaning program as specified in point 9.1 of Part II.
 - f. Where a dairy establishment produces food stuffs containing dairy products together with other ingredients, which have not undergone heat treatment or any other treatment having equivalent effect, such dairy products and ingredients shall be stored separately to prevent cross-contamination.
 - g. The production of heat-treated milk or the manufacture of milk-based products, which might pose a risk of contamination to other dairy products, shall be carried out in a clearly separated working area.

- h. Equipment, containers and installations which come into contact with dairy products or perishable raw materials used during production shall be cleaned and if necessary disinfected according to a verified and documented cleaning programme.
 - i. Equipment, containers, instruments and installations which come in contact with microbiologically stable dairy products and the rooms in which they are stored shall be cleaned and disinfected according to a verified and documented. Food Safety management programme drawn up by the owner/occupier of the dairy establishment.
 - j. Disinfectants and similar substances used shall be used in such a way that they do not have any adverse effects on the machinery, equipment, raw materials and dairy products kept at the dairy establishment. They shall be in clearly identifiable containers bearing labels with instructions for their use and their use shall be followed by thorough rinsing of such instruments and working equipment with potable water, unless supplier's instructions indicate otherwise.
2. Personal hygiene requirements
- a. The Food Business Operator shall employ those persons only in such an establishment to work directly with and handle raw materials or dairy products if those persons have proved to the occupier's satisfaction by means of a medical certificate, on recruitment, that there is no medical impediment to their employment in that capacity.
 - b. Persons working directly with and handling raw materials or dairy products shall maintain the highest standards of personal cleanliness at all times. In particular they shall
 - wear suitable, clean working clothes and headgear which completely encloses their hair;
 - wash their hands at least each time work is resumed and whenever contamination of their hands has occurred; e.g. after coughing / sneezing, visiting toilet, using telephone, smoking etc.
 - (cover wounds to the skin with a suitable waterproof dressing. No person with injury on hand, even with dressing, shall be placed in any product making/handling section.
 - avoid certain hand habits - e.g. scratching nose, running finger through hair, rubbing eyes, ears and mouth, scratching beard, scratching parts of bodies etc. that are potentially hazardous when associated with handling dairy products, and might lead to food contamination through the transfer of bacteria from the employee to product

during its preparation. When unavoidable, hands should be effectively washed before resuming work after such actions

3. Sanitary requirements for storage

- a. Immediately after procuring, raw milk shall be placed in a clean place, which is suitably equipped so as to prevent any kind of contamination.
- b. The cans/ containers made up of mild steel metal and plastic material used for storage and transportation of milk and milk products shall not be allowed.
- c. If raw milk is brought to the dairy plant by a producer or farmer then it shall be ensured that he brings it within four hours of milking and it shall be cooled as soon as practicable to a temperature of 4°C or lower and maintained at that temperature until processed.
- d. Where raw milk is collected daily from a producer, it shall be cooled immediately to a temperature of 4°C to 6°C or lower and maintained at that temperature until processed;
- e. When the pasteurization process is completed, pasteurized milk shall be cooled immediately to a temperature of 4°C or lower. Subject to Paragraph 7 below, any dairy product not intended to be stored at ambient temperature shall be cooled as quickly as possible to the temperature established by the manufacturer of that product as suitable to ensure its durability and thereafter stored at that temperature.
- f. Where dairy products other than raw milk are stored under cooled conditions, their storage temperatures shall be registered and the cooling rate shall be such that the products reach the required temperature as quickly as possible.
- g. The maximum temperature at which pasteurized milk may be stored until it leaves the treatment establishment shall not exceed 5°C.

4. Wrapping and packaging

- a. The wrapping and packaging of dairy products shall take place under satisfactory hygienic conditions and in rooms provided for that purpose.
- b. The manufacture of dairy products and packaging operations may take place in the same room if the following conditions are satisfied:
 - The room shall be sufficiently large and equipped to ensure the hygiene of the operations;
 - the wrapping and packaging shall have been brought to the treatment or processing establishment in protective cover in which they were placed immediately after

manufacture and which protects the wrapping or packaging from any damage during transport to the dairy establishment, and they shall have been stored thereunder hygienic conditions in a room intended for that purpose;

- the rooms for storing the packaging material shall be free from vermin and from dust which could constitute an unacceptable risk of contamination of the product and shall be separated from rooms containing substances which might contaminate the products. Packaging shall not be placed directly on the floor;
 - packaging shall be assembled under hygienic conditions before being brought into the room, except in the case of automatic assembly or packaging, provided that there is no risk of contamination of the products;
 - packaging shall be done without delay. It shall be handled by separate group of staff having experience in handling and product wrapping and
 - immediately after packaging, the dairy products shall be placed in the designated rooms provided for storage under required temperature.
- c. Bottling or filling of containers with heat-treated milk and milk product shall be carried out hygienically.
- d. Wrapping or packaging may not be re-used for dairy products, except where the containers are of a type which may be re-used after thorough cleaning and disinfecting.
- e. Sealing shall be carried out in the establishment in which the last heat-treatment of milk or liquid milk-based products have been carried out, immediately after filling, by means of a sealing device which ensures that the milk is protected from any adverse effects of external origin on its characteristic. The sealing device shall be so designed that once the container has been opened, the evidence of opening remains clear and easy to check.

3.3 Packaging and Labelling

The packaging design and materials shall provide protection for products in order to prevent contamination, damage and accommodate required labelling as laid down under the FSS Act and the Regulations there under. Only food grade packaging materials shall be used as primary packaging material. Packaging materials like aluminium, tin and plastic shall conform to the Indian standards as mentioned under the FSS Regulations from time to time. The food packaging materials shall be inspected before use to avoid using damaged, defective or contaminated packaging, which may lead to contamination of the product.

- The wrapping and packaging of dairy products shall take place under satisfactory hygienic conditions and in rooms provided for that purpose.
- The rooms for storing the packaging material shall be free from vermin and from dust which could constitute an unacceptable risk of contamination of the product and shall be separated from rooms containing substances which might contaminate the products. Packaging shall not be placed directly on the floor.
- Packaging shall be done without delay followed by labelling. If it is not the case, appropriate procedure shall be applied to ensure that no mix-ups or mislabelling could occur. It shall be handled by separate group of staff having experience in handling and product wrapping and immediately after packaging; the dairy products shall be placed in the designated rooms provided for storage under required temperature.
- Packaging material/wrapping materials shall be protected from external environment/contamination during transport and storage. Facilities shall be established for safe and hygienic storage of packing materials at the dairy plant.”
- Wrapping or packaging may not be re-used for dairy products, except where the containers are of a type which may be re-used after thorough cleaning and disinfecting.
- “Packaging of milk and milk products shall be carried after processing. The packages should be designed so as to ensure they are tamper proof and are not easily damaged during general handling /operation. Once the packages are opened it should be easily identifiable and cannot be duplicated against a fresh/unopened package”.
- The ink used for printing of primary food packaging should be of food grade quality. This should comply with **IS 15495** standards or other international standards for use in food packaging and printing.

3.4 Selection of Packing Material

1. Pouch: Normally it is a three-layer pouch

- i) Metallocin LLDPE
- ii) LDPE
- iii) LLDPE



2. Bottle

- i) Glass Bottle
- ii) PET Bottle
- iii) PP Bottle



c. Tetra-bricks



3.5 Coding and Labelling of Packaging Material

Fluid milk: The caps of the milk bottles /pouch/tetra-bricks shall clearly indicate the nature of the milk contained in them. The indication may be either in full or by abbreviation shown below:

- i) Buffalo milk may be denoted by the letter ‘B’.
- ii) Cow milk may be denoted by the letter ‘C’

- iii) Goat milk may be denoted by the letter ‘G’
- iv) Standardized milk may be denoted by the letter ‘S’
- v) Toned milk may be denoted by the letter ‘T’
- vi) Double toned milk may be denoted by the letter ‘DT’
- vii) Skimmed milk may be denoted by the letter ‘K’
- viii) Pasteurised milk may be denoted by the letter ‘P’; followed by the class of milk. For example, Pasteurised Buffalo milk shall bear the letters ‘PB ‘.
- ix) Alternatively, suitable indicative colours of the packs/caps/bags shall be indicative of the nature of milk contained in them, the classification of colours being displayed at places where milk is sold/stored or exhibited for sale, provided that the same had been simultaneously intimated to the concerned Designated Officer, and information disseminated through the local media

3.6 Exemptions from labelling requirements

Where the surface area of the package is not more than 100 square centimetres, the label of such package shall be exempted from the requirements of list of ingredients, Lot Number or Batch Number or Code Number, nutritional information and instructions for use, but this information shall be given on the wholesale packages or multi piece packages, as the case may be.

1. The 'date of manufacture' or 'best before date' or 'expiry date' may not be required to be mentioned on the package having surface area of less than 30 square centimetres but this information shall be given on the wholesale packages or multipiece packages, as the case may be;
2. In case of liquid products marketed in bottles, if such bottle is intended to be reused for refilling, the requirement of list of ingredients shall be exempted, but the nutritional information specified in regulation 2.2.2 (4) these regulations shall be given on the label. Provided that in case of such glass bottles manufactured after March 19, 2009, the list of ingredients and nutritional information shall be given on the bottle.
3. “To make a fluid not below the composition of toned milk or skimmed milk (as the case may be) with the contents of this package, add (here insert the number of parts) of water by volume to one part by volume of this condensed milk or desiccated (dried) milk”.

4. In case of food with shelf-life of not more than seven days, the 'date of manufacture' may not be required to be mentioned on the label of packaged food articles, but the 'use by date' shall be mentioned on the label by the manufacturer or packer.
5. In case of multi piece packages the particulars regarding list of ingredients, nutritional information, Date of manufacture/ packing, best before, expiry date labelling of irradiated food and, vegetarian logo/non vegetarian logo, may not be specified.

3.7 Date of manufacture or packing

The date, month and year in which the commodity is manufactured, packed or pre-packed, shall be given on the label:

Provided that the month and the year of manufacture, packing or pre-packing shall be given if the “Best Before Date” of the products is more than three months:

Provided further that in case any package contains commodity which has a short shelf life of less than three months, the date, month and year in which the commodity is manufactured or prepared or pre-packed shall be mentioned on the label.

Best Before and Use By Date

- i) the month and year in capital letters up to which the product is best for consumption, in the following manner, namely:

“BEST BEFORE MONTHS AND YEAR

OR

“BEST BEFORE MONTHS FROM PACKAGING

OR

“BEST BEFOREMONTHS FROM MANUFACTURE

(Note: — blank be filled up)

- ii) In case of package or bottle containing sterilised or Ultra High Temperature treated milk, soya milk, flavoured milk, any package containing bread, dhokla, bhelpuri, pizza, doughnuts, khoa, paneer, or any un canned package of fruits, vegetable, meat, fish or any other like commodity, the declaration be made as follows:

“BEST BEFOREDATE/MONTH/YEAR”

OR

“BEST BEFORE.....DAYS FROM PACKAGING”

OR

“BEST BEFOREDAYS FROM MANUFACTURE”

Note:

(a) blanks be filled up

(b) Month and year may be used in numerals (c) Year may be given in two digits

(iii) On packages of Aspartame, instead of Best Before date, Use by date/recommended last consumption date/expiry date shall be given, which shall not be more than three years from the date of packing;

(iv) In case of infant milk substitute and infant foods instead of Best Before date, Use by date/recommended last consumption date/expiry date shall be given, Provided further that the declaration of best before date for consumption shall not be applicable

3.8 Documentation and Record Keeping

Every organization has to maintain records of raw material procurement, production processes, and sales. This is to ensure that the business runs effectively and is profitable. Listed below are some reasons why there is a need for documentation:

1. It gives detailed knowledge about running the business.
2. It helps to control product quality.
3. It helps to keep track of the money invested in the business.
4. It helps to identify the separate costs of raw material or product ingredients.
5. It helps to identify the production cost of a particular process.
6. It helps to make sure that all the quality assurance practices were followed during the production.
7. It helps to make sure that the production equipment is running smoothly/effectively.
8. It works as an evidence for legal procedures.
9. It helps to set an appropriate product price.

10. It helps to take corrective measures at the right time.

How to Keep Records

Every food processing organization follows a more or less similar way of keeping records.

Production records keep a log of the following:

- The quantity and type of raw materials received
- The quantity and type of ingredients used during processing
- The processing conditions in which production took place (e.g. the temperature set or the air pressure applied)
- The product quality produced

Product quality can be maintained only when:

- The same quantity and quality of ingredients and raw materials are mixed in every batch
- A standard formulation is used for every batch
- Standard process parameters are applied for every batch

Every batch of food is given a batch number. This number is recorded in:

- Stock control books (where raw material procurement is noted)
- Processing logbooks (where production process is noted)
- Product sales records (where sales and distribution is noted)

The batch number must correlate with the product code number, which is printed on labels. This helps the processor to trace any fault found in a batch back to the raw material used or the production process

Chapter – 4

Cleaning and CIP

4.1 Tanker Washing

The main objective of this unit is to clean the tankers properly after unloading or before uploading milk or any other dairy ingredients to avoid microbial and bacterial growth.

Stepwise washing operation:

- Circulate Caustic solution for 15min. (1 – 1.5%) at 70 – 75⁰C.
- Flush out Caustic with water.
- Circulate with hot water for 15min. (80 – 85⁰C)
- Allow temperature to cool down
- Get QA clearance

4.2 Crate Washing:

Normally a semi-automatic crate washer is used for cleaning the crates. The washer cleans the crates in stages

Solid waste removal – Manually

1. Pre-rinse
2. Hot water and caustic solution
3. Final rinsing

4.3 CIP of Raw milk and Process milk storage tank

- Flush Silo with necessary water
- Clean (by brushing) the door of the manhole and sampling point with soap oil and water.
- Circulate Caustic solution for 20min. (1 – 1.5%) at 70 – 75⁰C.
- Flush out Caustic with water.
- Circulate with acid for 20min. (0.6 – 1.0%) at 60 – 65⁰
- Circulate with hot water for 20min. (80 – 85⁰C)
- Allow temperature to cool down

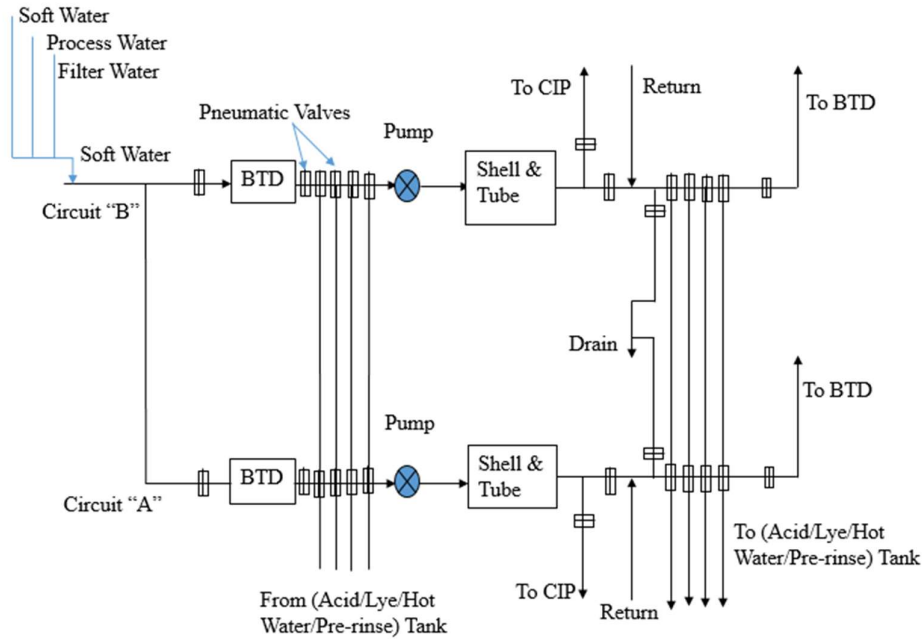

Fig: A two station CIP Circuit

4.4 Effluent Treatment Plant (ETP)

ETP is a 24 hrs. continuous process. It takes hazardous outlet from all the process as inlet, treat it in three stages (Primary, Secondary and Tertiary stage) to reach the environmental standard. The outlets of the plant namely solid waste and treated water are respectively disposed in field and used for irrigation purpose in plant to develop green belt.

Effluent Sources:

1. CIP: Caustic and Nitric Acid
2. Backwash: Water
3. Tanker wash: Caustic and Nitric Acid
4. Boiler: Water
5. Caret wash: Caustic

Stepwise description of ETP functioning:

- 1) Screen chamber: Raw effluent from the plant is received by screen chamber and suspended particles are removed here.
- 2) Collection and equalization tank: After the screening the effluent enters the collection and equalization tank, where it is neutralized with hydrochloric acid and the effluent is made homogeneous.

- 3) Holding tank: It only meant for storage when excess amount of effluent is discharged from plant during CIP
- 4) Dissolved Air Flootation (DAF): The neutralized effluent from collection and equalization tank is received here and aluminum sulphate (a non-ferric alum) is added. The suspended and emulsified solids are separated here.
- 5) Buffer tank: It is an over flow storage tank
- 6) Up blow Anaerobic Suspended Sludge Blanket (UASSB) Reactor (I&II): 12% to 15% of the total volume of this tank is filled with biomass. It receives the effluent from DAF from the bottom of the tank. There are two type of bacteria present here.
 - a. Acetogenesis: - It converts the large chain molecule to small chain molecule and produces amino acid.
 - b. Methenogenesis: - It converts to methane gas, and hence organic load decreases
- 7) Hopper bottom tank: It is just a tank to control the escaped microbes from UASSBR and again recirculate it.
- 8) Aeration tank: In this tank aerobic microbes are developed
- 9) Lamella clarifier: It is used for solid settling purpose i.e. the solid liquid separation takes place here
- 10) Secondary clarifier: Here the aerobic culture is settled and again circulated to aeration tank to maintain the amount.
- 11) Treated water tank: Here the treated water from secondary clarifier or lamella clarifier is collected.

Plant Performance and Monitoring:

- Carryout regular monitoring program involving maintenance of record and analysis of effluent sample.
- ETP assistants have to collect samples at different stages of treatment system in presence of ETP in-charge for analysis.
- ETP in-charge has to do the analysis and record the result also report the result to EHS-engineer and EHS-officer. EHS-engineer and EHS-officer both will assess the performance of the plant based on laboratory analysis report and instruct the ETP in-charge and assistants about the action to be taken in case of any deviation from normal.
- The treated effluent has to be analyzed on daily basis and the results are recorded

Environmental Management System (EMS): Implementation and operation:

- 2. Level-1:** EMS manual; describes the core elements of the EMS and their interactions. It outlines the structure of the document used in the EMS in line with- ISO 14001-2004 manual also describe the procedures elaborately how various requirements of ISO 14001-2004 are implemented.
- 3. Level-2:** Documents; the filled formats which conveys the data that affects the environment. Ex – Operational control process, environmental management programs, emergency procedures, monitoring and management plans, training plan etc.
- 4. Level-3:** Formats; used for recording and conveying data effecting the environment